

READ AND SAVE THESE INSTRUCTIONS



TCB *Tubular Centrifugal Inline Fan*
TCBRU *Centrifugal Upblast Fan*
TCBRS *Centrifugal Roof Supply Fan*

Installation Operation and Maintenance Manual



TCB Inline
Level 1 & 2



TCBRU Roof Upblast
Level 1 & 2



TCBRS Roof Supply
Level 1 & 2

RECEIVING

Greenheck models TCB, TCBRU, and TCBRS are thoroughly inspected and test run at the factory. Items such as proper wheel alignment, balance, vibration and workmanship are analyzed by quality control personnel using state-of-the-art equipment. However, damage may occur during handling and shipping. Therefore, it is important that the unit be carefully inspected for visible and concealed damage before beginning installation. In addition, check to see that all accessory items are accounted for.

REPORT ANY DAMAGED EQUIPMENT TO THE SHIPPER IMMEDIATELY!

HANDLING

Fans are to be rigged by either the lifting brackets provided or by the skid when a forklift is used. All TCB Inline models have mounting brackets located at the ends of the fan housing with which slings can be attached (Fig. 1). All TCBRU Roof Upblast models can be lifted by lifting lugs located above the motor cover of the fan (Fig. 2). All TCBRS Roof Supply fans can be lifted by lugs located on the hood rails (Fig. 3).

Fans should NOT be lifted by the shaft, housing, motor, belt guard, or any accessories.



Fig. 1

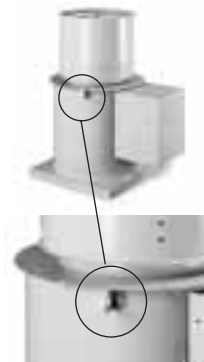

Fig. 2

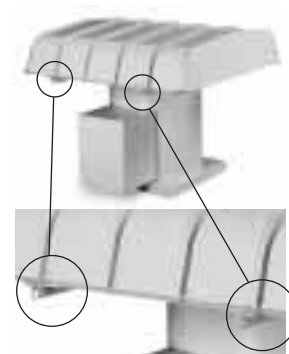

Fig. 3

STORAGE - Indoor and Outdoor

When a fan is to be stored for a period of time, it must be protected from dirt and moisture. Use of a tarp to cover the unit will aid in keeping it clean and dry, but avoid using a black plastic tarp as it will promote condensation. Improper storage which results in damage to the fan will void the warranty. If the storage period is lengthy, the wheel and motor should be rotated periodically and the bearings purged with fresh grease. In humid, dusty, or corrosive atmospheres, rotate the fan and purge the bearings once a month. Under normal conditions, this procedure should be repeated once every three months.

INSTALLATION

EFFECT OF INSTALLATION ON PERFORMANCE

Any installation with inlet or discharge configurations that deviate from these recommendations may result in reduced fan performance. Restricted or unstable flow at the fan inlet can cause pre-rotation of incoming air or uneven loading of the fan wheel yielding large system losses and increased sound levels. Free discharge or turbulent flow in the discharge ductwork will also result in system effect losses.

The most common inlet and discharge conditions which affect fan performance are:

INLET DUCT TURNS

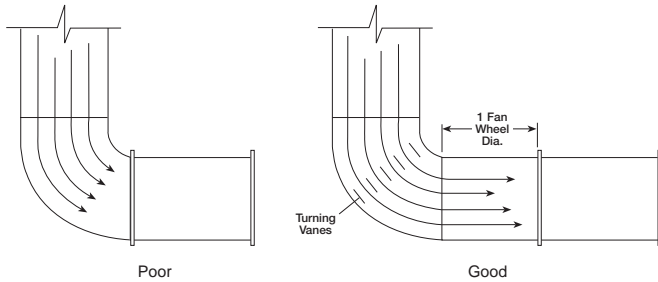

Installation of a duct turn or elbow too close to the fan inlet reduces fan performance because air is loaded unevenly into the fan wheel. To achieve full fan performance there should be at least one to two fan wheel diameters between the turn or elbow and the fan inlet.

DISCHARGE DUCT TURNS

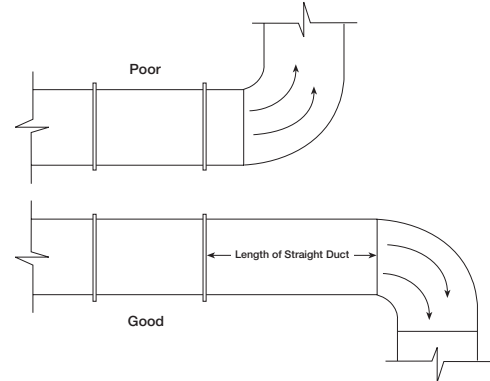

Fan performance is reduced when duct turns are made immediately off the fan discharge. To achieve cataloged fan performance, there should be at least one equivalent duct diameter of straight ductwork between the fan discharge and any duct turns.

TYPICAL INSTALLATIONS

Following are typical mounting installations for models TCB (horizontal or vertical mounting), TCBRU, and TCBRS. For TCB's with motor in the 3 or 9 o'clock position or vertical installations, additional mounting rails are recommended. Mounting rail dimensions are shown for field fabrication.

Horizontal Ceiling Hung

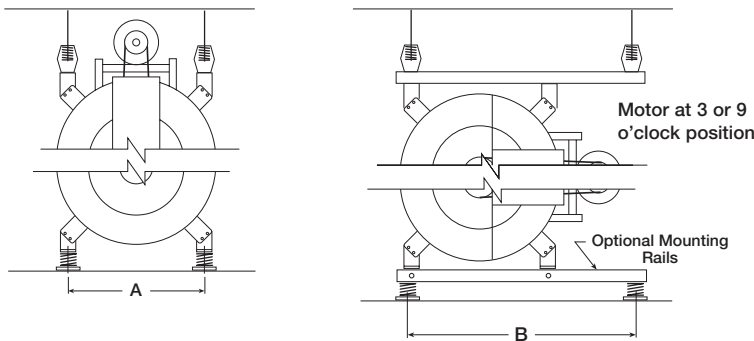

Horizontal Base Mount

Vertical Ceiling Hung

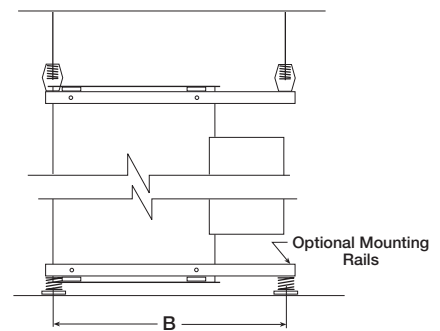

Vertical Base Mount w/ airflow up or down

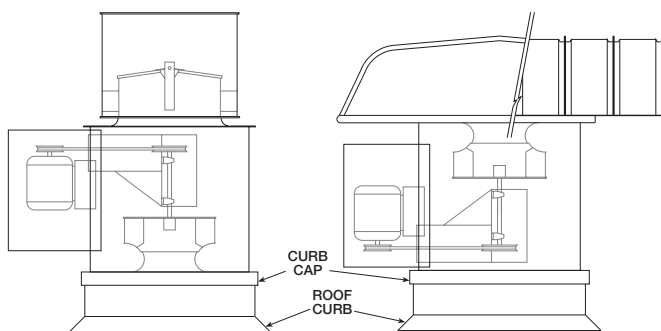

**TCBRU Installation
Curb Mounted**

**TCBRS Installation
Curb Mounted**

Mounting Hole Location

Fan Size	A	B	Depth*	Roof Opening	
				TCBRU	TCBRS
9	17 ¹ / ₂	26	18 ³ / ₈	14 x 14	16 x 16
10	17 ¹ / ₂	26	18 ³ / ₈	14 x 14	16 x 16
12	17 ¹ / ₂	26	18 ³ / ₈	14 x 14	16 x 16
13	19	28 ¹ / ₂	19 ⁷ / ₈	16 x 16	18 x 18
16	21 ³ / ₄	33	23 ⁷ / ₈	18 x 18	22 x 22
18	26 ¹ / ₄	37	26 ³ / ₈	20 x 20	28 x 28
22	30 ¹ / ₂	44	29 ⁵ / ₈	24 x 24	34 x 34
24	35	50	33 ¹ / ₈	26 x 26	40 x 40
30	42	56	42 ⁵ / ₈	32 x 32	46 x 46
36	46 ³ / ₄	62	48 ¹ / ₈	38 x 38	52 x 52

*Depth dimension is the center distance between holes in the front and rear mounting brackets

OPERATION

ELECTRICAL CONNECTIONS

Before electrical connections are made, the supply voltage, phase and ampere capacity must be checked for compatibility with the fan motor. In addition, the supply wiring must be properly fused and conform to local and national electrical codes.

The supply wires are then connected to an **optional** safety disconnect switch (if supplied) or wired directly to the motor.

PRE-START UP CHECKS

1. Check all fasteners for tightness.
2. The wheel should be aligned as shown in Fig. 4. Although the wheel position is preset and the unit is test run at the factory, movement may occur during shipment.

The radial gap should be consistent at all locations between the centrifugal wheel and the inlet cone. Centering may be accomplished by loosening the inlet cone bolts and repositioning the inlet cone.

To obtain the optimum performance, the centrifugal wheel must overlap the inlet cone. Adjustments can be made by loosening the set screws in the wheel and moving the wheel to the desired position.

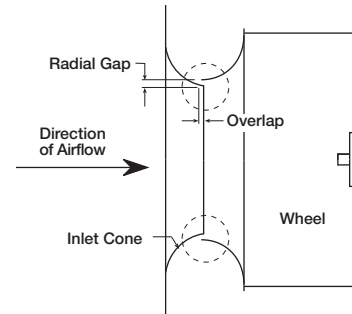

Fig. 4

3. Wheel rotation should be in the same direction as the rotation decal affixed to the unit. For 3-phase installations, fan rotation can be reversed by simply interchanging any two of the three electrical leads. For single phase installations, follow the wiring diagram located on the motor.
4. Adjustable motor pulleys are preset at the factory for the specified fan RPM. Fan speed can be increased by closing or decreased by opening the adjustable pulley. Two or three groove variable pitch pulleys must be adjusted an equal number of turns open or closed.

Note: Any increase in fan speed represents a substantial increase in horsepower required from the motor. Always check motor load amperage and compare to name plate rating when changing fan speed.

MAINTENANCE

WARNING

DISCONNECT AND SECURE TO THE "OFF" POSITION ALL ELECTRICAL POWER TO THE FAN PRIOR TO INSPECTION OR SERVICING. FAILURE TO COMPLY WITH THIS SAFETY PRECAUTION COULD RESULT IN SERIOUS INJURY OR DEATH.

Once the fan has been put into operation, a periodic maintenance program should be set up to preserve the reliability and performance of the fan. Items to be included in this program are:

- BEARINGS
- BELTS
- FASTENERS
- SET SCREWS
- MOTORS
- REMOVAL OF DUST/DIRT

BEARINGS

Bearings are the most critical moving part of the fan and should be inspected at periodic intervals. Locking collars and set screws, in addition to fasteners attaching the bearing to the bearing plate, must be checked for tightness. In a clean environment and temperature above 32°F and below 200°F, fan shaft bearings with grease fittings should be lubricated semi-annually using a high quality lithium based grease. If unusual environmental conditions exist such as temperatures below 32°F and above 200°F, moisture or contaminants, more frequent lubrication is required.

With the unit running, add grease very slowly with a manual grease gun until a slight bead of grease forms at the seal. Be careful not to unseat the seal by over lubricating or using excessive pressure. Bearings without grease fittings are lubricated for life.

BELTS

Premature belt failures are frequently caused by improper belt tension (either too tight or too loose) or misaligned pulleys. The proper tension for operating a V-belt is the lowest tension at which the belts will not slip at peak load conditions. For initial tensioning, the proper belt deflection half-way between pulley centers is $\frac{1}{64}$ " for each inch of belt span. For example, if the belt span is 64 inches, the belt deflection should be one inch using moderate thumb pressure at midpoint of the drive. See Fig. 5.

Check belt tension two times during the first 24 hours of operation and periodically thereafter. To adjust belt tension, simply loosen four fasteners (two on each side of the motor plate) and slide the motor plate away from the fan shaft until proper belt tension is attained. On some fans, fasteners attaching the motor to the motor plate must be loosened in order to adjust the belt.

It is very important that the drive pulleys remain in proper alignment after adjustments are made. Misalignment of pulleys will result in premature belt wear, noise, vibration and power loss. See Fig. 6.

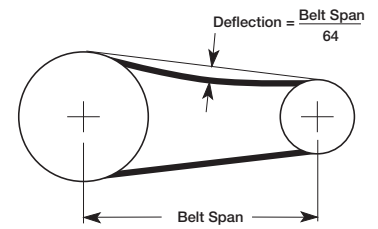

Fig. 5

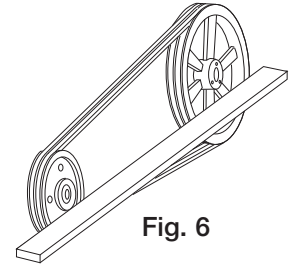

Fig. 6

FASTENERS AND SET SCREWS

A periodic inspection should include checking all fasteners and set screws for tightness. Particular attention should be paid to set screws attaching the propeller to the shaft and the shaft to the bearings. Loose bearing set screws will lead to premature failure of the fan shaft.

MOTORS

Many fractional horsepower motors installed on the smaller fans are lubricated for life and require no further attention. Motors supplied with grease fittings should be greased according to directions printed on the motor.

REMOVAL OF DUST AND DIRT

Dirt clogs cooling openings on the motor housing, contaminates bearing lubricant, and collects on the impeller causing severe imbalance if left unchecked. The exterior surface of the motor and impeller should be thoroughly cleaned periodically. Use caution and do not allow water or solvents to enter the motor or bearings. Under no circumstances should motors or bearings be sprayed with steam or water.

DAMPER INSPECTION AND SERVICE (Model TCBRU Level 1 or 2)

Butterfly dampers should be inspected for proper operation at each service interval. Check for freedom of movement and general condition of the damper blades and hinge rods.

PARTS LIST

Each fan bears a manufacturer's nameplate with model number and serial number embossed. This information in addition to the parts list shown will assist the local Greenheck representative and the factory in providing service and replacement parts.

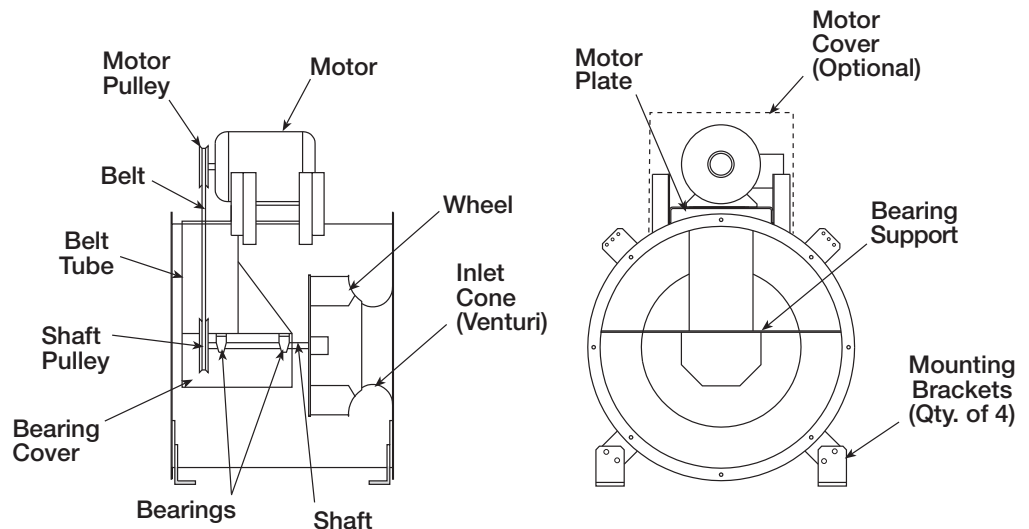

WARRANTY

Greenheck warrants this equipment to be free from defects in material and workmanship for a period of one year from the purchase date. Any units or parts which prove to be defective during the warranty period will be repaired at our option when returned to our factory, transportation prepaid.

The motor is warranted by the motor manufacturer for a period of one year. Should the motor prove defective during this period, it should be returned to the nearest authorized motor service station.

Greenheck will not be responsible for any installation or removal costs.