

Installation, Operation, and Maintenance Instructions

This manual is the property of the owner, and is required for future maintenance. Please leave it with the owner when the job is complete.

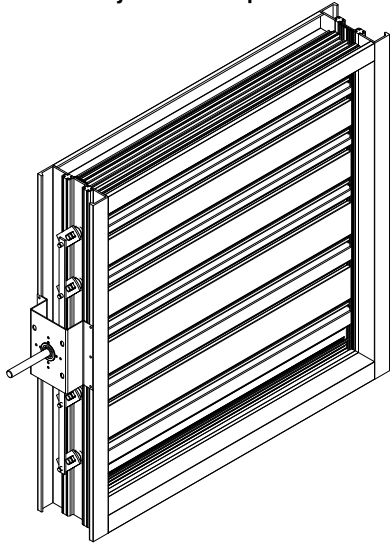

RECEIVING AND HANDLING

Upon receiving dampers, check for both obvious and hidden damage. If damage is found, record all necessary information on the bill of lading and file a claim with the final carrier. Check to be sure that all parts of the shipment, including accessories, are accounted for. Dampers must be kept dry and clean. Indoor storage and protection from dirt, dust and the weather is highly recommended. Do not store at temperatures in excess of 100°F(37°C).

SAFETY WARNING:

Improper installation, adjustment, alteration, service or maintenance can cause property damage, injury or death. Read the installation, operating, and maintenance instructions thoroughly before installing or servicing this equipment.

Due to continuing research, Greenheck reserves the right to change specifications without notice.

Pre-Installation Guidelines

The basic intent of a proper installation is to secure the volume control damper into the opening in such a manner as to prevent distortion and disruption of damper operation. The following items will aid in completing the damper installation in a timely and effective manner.

- 1) Check the schedules for proper damper locations within the building. Visually inspect the damper for damage.
- 2) Lift or handle damper using sleeve or frame. Do not lift damper using blades, linkage, actuators, or jackshifting. When handling multiple sections assemblies, use sufficient support to evenly lift at each section mullion (see drawing). Do not drag, step on, apply excessive bending, twisting, or racking.
- 3) Do not install screws in damper frame that will interfere with unexposed blade linkage and prevent damper blades from opening and/or closing.
- 4) Damper must be installed into duct or opening square and free of twist or other misalignment. Damper must not be squeezed or stretched into duct or opening. Out of square, racked, twisted or misaligned installations can cause excessive leakage and/or torque requirements to exceed damper/actuator design.
- 5) Damper and actuator must be kept clean, dry and protected from dirt, dust and other foreign materials prior to and after installation. Examples of such foreign materials include but are not limited to:
 - a) Mortar dust
 - b) Drywall dust
 - c) Firesafing materials
 - d) Wall texture
 - e) Paint overspray
- 6) Damper should be sufficiently covered as to prevent overspray if wall texturing or spray painting will be performed within 5 feet (1.50m) of the damper. Excessive dirt or foreign material deposits on damper can cause excessive leakage and/or torque requirements to exceed damper/actuator design.
- 7) **ACCESS:** Suitable access (actuators maintenance, etc.) must be provided for damper inspection and servicing. Where it is not possible to achieve sufficient size access, it will be necessary to install a removable section of duct.

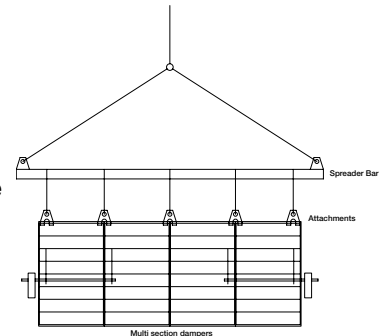

Electrical Guidelines

Electrical and/or pneumatic connections to damper actuators should be made in accordance with wiring and piping diagrams developed in compliance with applicable codes, ordinances and regulations.

SAFETY CAUTION !
Verify power requirements before wiring actuator. Greenheck is not responsible for any damage to, or failure of the unit caused by incorrect field wiring.

SAFETY DANGER !
Electrical input may be needed for this equipment. This work should be performed by a qualified electrician.

Installation - Failure to follow instructions will void all warranties

- 1, Duct opening or opening square should measure to the inside damper dimension and should be straight and level.
2. A damper assembly is not restricted to a maximum number of sections, but must not exceed the section sizes and overall sizes shown below.

Damper Model	Maximum Single Section Size	Maximum Multi-Section Size
ICD-44	48 in. W x 74 in. H (1219mm W x 1880mm H)	144 in. W x 148 in. H (3658mm W x 3759mm H)
ICD-45	48 in. W x 74 in. H (1219mm W x 1880mm H)	144 in. W x 120 in. H (3658mm W x 3048mm H)

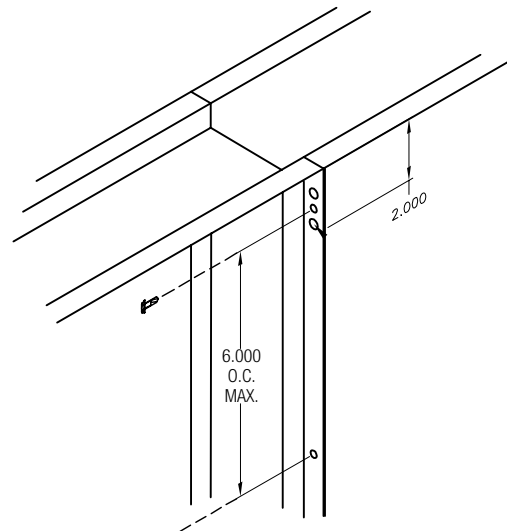
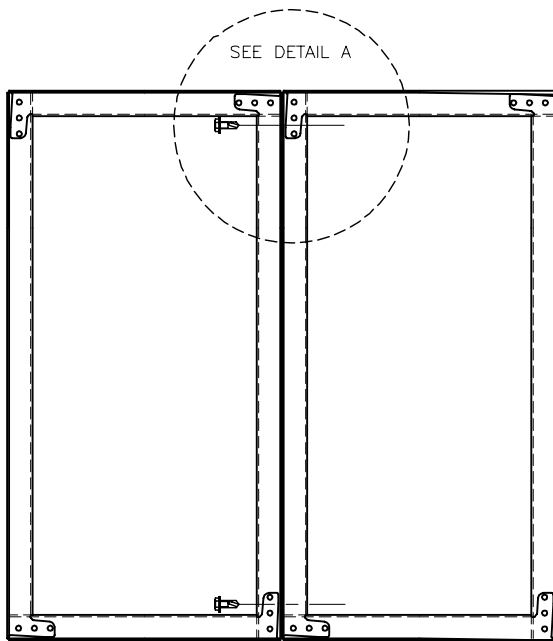

Figure 1

Figure 2

3. The damper sections must be attached together with #10 x 3/4 inch (19mm) max. sheet metal screws, 1/4 inch (6mm) diameter nuts and bolts, tack or spot welds or 3/16 inch (4mm) diameter steel pop rivets. Attachments must be spaced a maximum of 6 inch (152mm) on centers and a maximum of 2 inch (51mm) from corners. Attachments must be made on front face and back face (air entering and air exiting side) of damper sections (see Figure 1 & 2).
4. If no holes are present in frame, drill 1/4 inch (6mm) diameter holes at 6 inch (152mm) centers and fasten frames together with 1/4 inch (6mm) #20 (.03mm) bolts and nuts.
5. Brace at every horizontal mullion and vertically brace at every 8 feet (2.4m) of damper width for strength. Dampers in high velocity (2000 fpm [610m per second]) may require more bracing. Note: Greenheck dampers are specifically designed and engineered for structural integrity based on model and conditions. Attachment, framing, mating flanges, and anchoring of damper assemblies into openings, ductwork, or walls is the responsibility of the installer. Design calculations for these retaining and supporting members should be determined by field engineers for that particular installation.

Installation (continued)

- If damper actuator is to be mounted out of the airstream, the extension pin should extend approximately 6 inches (152mm) beyond the frame. On jackshafted units, the jackshaft should extend through the jackshaft bearing assembly and approximately, 6 inches (152mm) beyond the frame.
- Individual damper sections, as well as entire multiple section assemblies must be completely square and free from racking, twisting, or bending. Measure diagonally from upper corners to opposite lower corners of each section (see Figure 3 & 4).
- Damper blades, axles, and linkage must operate without binding. Before system operation, cycle dampers after installation to assure proper operation. On multiple section assemblies, all sections should open and close simultaneously.

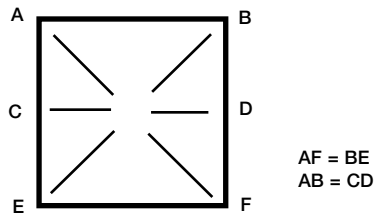

Figure 3

Do not twist or bow. Mount damper plumb in the opening.

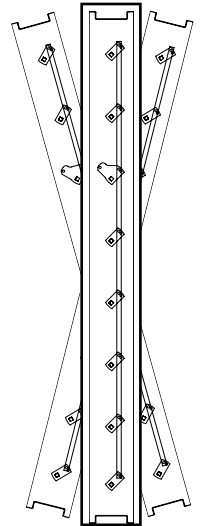

Figure 4

Quick Connect Frame

- These instructions apply to quick connect frame attaching to a TDC or TDF flange system.
- To seal the two flange systems together Neoprene or Butyl gasket may be applied to the mating surfaces (Figure 5).
- Align the quick connect frame and flange system together. An optional 3/8 in. (9mm) bolt may be used in the corners to help with the alignment. These bolts do not have to be removed.
- Install the metal cleat (Figure 6) or #10 tek screw with following recommended spacing:
 - Width or height less than 24 in. (610mm); use one cleat or screw per side
 - Width or height 24 in. (610mm) to less than 36 in. (914mm); use 2 cleats or screws per side
 - Width or height 36 in. (914mm) to less than 54 in. (1372mm); use 3 cleats or screws per side
 - Width or height 54 in. (1372mm) to less than 72 in. (1829mm); use 4 cleats or screws per side
 - Width or height 72 in. (1829mm) or greater; use 5 cleats or screws per side.

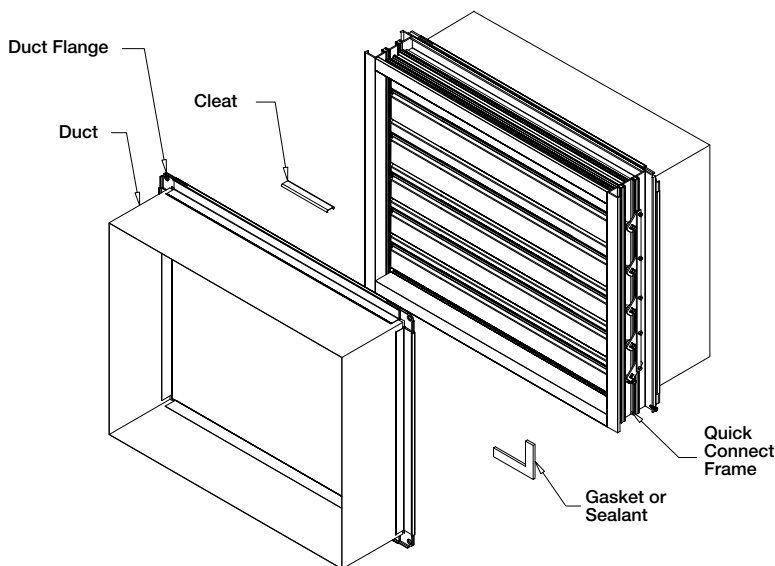

Figure 5: Quick Connect Frame

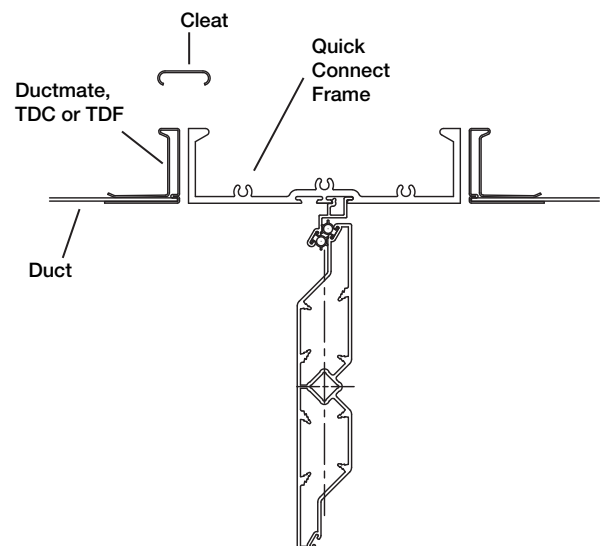

Figure 6

Damper Maintenance

Greenheck's dampers are designed to be trouble free and hassle free under normal operation. Dampers are to be installed square and straight so as to prevent binding during operation. The following annual damper maintenance suggestions will help to insure proper damper operation and increase the life expectancy of the damper.

- Foreign Matter** Over the course of time, dirt and grime may collect on damper surfaces. The damper surfaces should be cleaned to prevent hindrance to airflow.
- Moving Parts** Make sure that parts such as linkage, bearings, blades, etc. that are intended to move freely, can do so. Lubricating these components can prevent possible rusting and unnecessary friction increase. Use only a moli-spray oil or similar graphite based oil as regular lubricating oil will attract dirt.
Bearings. Synthetic, oil impregnated, and ball bearings (without grease fittings) do not require lubrication. Ball bearings with grease fittings require only minimal grease.
- Closure** Remove foreign materials that may be interfering with blade closure or effective sealing of the blades with each other or with the frame.
- Operation** While operating the damper through its full cycle, check to see that the blades open and close properly. If there is a problem, check for loose linkage, especially at the actuator. Tighten the linkage where required.

Damper Trouble Shooting

The following is a cause and correction list for common concerns with the dampers.

Symptom	Possible Cause	Corrective Action
Damper does not fully open and/or fully close	Frame is 'racked' causing blades to bind on jamb seals	Adjust frame such that it is square and plumb
	Actuator linkage loose	Close damper, disconnect power, adjust and tighten linkage
	Defective motor	Replace
	Screws in damper linkage	Locate screws and remove
	Actuator linkage hitting wall or floor	Damper installed too far into wall. Move out to designated line on damper label
	Contaminants on damper	Clean with a non-oil-based solvent (see Damper Maintenance)

Our Commitment

As a result of our commitment to continuous improvement, Greenheck reserves the right to change specifications without notice. Specific Greenheck product warranties are located on greenheck.com within the product area tabs and in the Library under Warranties.



Phone: (715) 359-6171 • Fax: (715) 355-2399 • E-mail: gfcinfo@greenheck.com • Website: www.greenheck.com